

Standard Preparation 1200 mm Meat & Fish Processing/Washing Table

ITEM # _____

MODEL # _____

NAME # _____

SIS # _____

AIA # _____



132960
(TLC1210PN)

Meat and fish processing/washing table with perforated and removable plates, knife holder, polythene cutting board, drain, scraping hole and upstand, 1200mm

Short Form Specification

Item No. _____

50mm high worktop in 304 AISI stainless steel, 1mm in thickness. Integral radiused rear upstand, h=100mm. All-round apron. Square section legs 40x40mm on 1" height-adjustable feet in 304 AISI stainless steel. Knife holder. N.1 polythene cutting board 730x225x25h mm on front and waste scraping hole.

Main Features

- Sturdiness, stability and reliability of table accurately tested.

Construction

- Table can be equipped with a mobile bin with lid for waste disposal (optional accessory).
- 50 mm worktop in 304 AISI stainless steel, 10/10 in thickness with upturned edges and reinforced waterproof underpanel, incorporates a layer of sound deadening materials.
- Square section legs and 40 mm height-adjustable feet in 304 AISI stainless steel.
- Unit features a 20 mm deep recessed surface, a polythene cutting board and a scraping hole on the front, perforated and sectionated removable tops, an easily removable GN liquid container and a knife holder. Knife sanitizer can be supplied as optional.

Optional Accessories

- Lower shelf for 1200mm tables and sinks and for 1800 mm undercounter dishwasher sinks PNC 855145
- Set of 4 wheels (2 with brake) d. 100mm for tables and sinks (total height on wheels= 993 mm) PNC 855150
- 3-sided underframe for 1200mm tables PNC 855152
- Single drawer GN 1/1, 400mm PNC 855280
- Single drawer, 600mm PNC 855281
- Additional drawer, 600mm (to set up a chest of 2, 3, 4 drawers) PNC 855295
- Additional drawer GN 1/1, 400mm (to set up a chest of 2, 3, 4 drawers) PNC 855298
- Elbow operated mixer tap with spout, 3/4" single hole PNC 855322
- Elbow operated mixer tap short spout, 3/4" single hole PNC 855323
- Foot operated Mixer tap with spout & with hot&cold pedals, 3/4" PNC 855328

APPROVAL: _____

Front

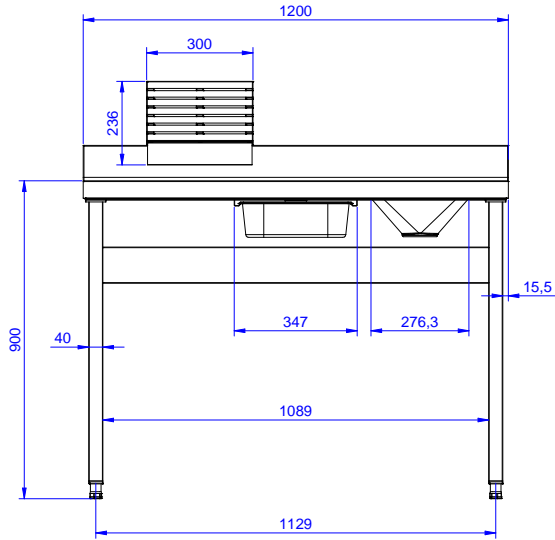

Side

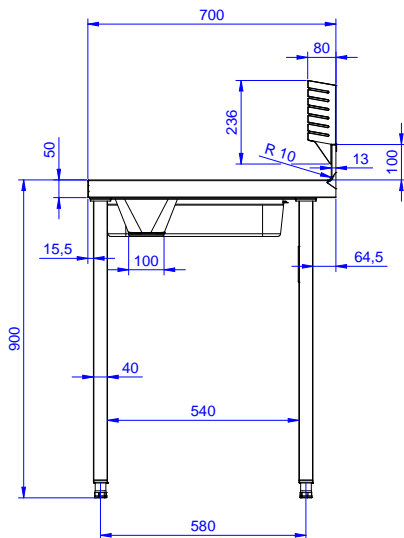

D = Drain

Top

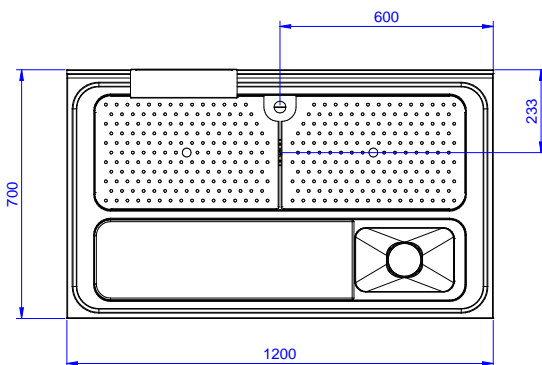

Key Information:

External dimensions, Width:	
132960 (TLC1210PN)	1200 mm
External dimensions, Depth:	700 mm
External dimensions, Height:	900 mm
Upstand Dimensions, Height:	100 mm
Upstand Dimensions, Depth:	13 mm
Upstand Dimensions, Radius:	R=10
Bowls number	1
Bowl dimensions	1070x320xH180
Number of cutting boards	1
Cutting board dimensions - width	810 mm
Cutting board dimensions - depth	230 mm
Cutting board dimensions - height	25 mm
Worktop thickness:	50 mm
Net weight:	40 kg